

# Weldability

## AN INTRODUCTION TO MANUAL METAL ARC (MMA) “STICK” WELDING

www group | [support@weldability.com](mailto:support@weldability.com)

**WARNING:**

This document contains general information about the topic discussed herein. This document is not an application manual and does not contain a complete statement of all factors pertaining to that topic.

The installation, operation and maintenance of arc welding equipment and the employment of procedures described in this document should be conducted only by qualified persons in accordance with applicable codes, safe practices, and manufacturers' instructions.

Always be certain that work areas are clean and safe and that proper ventilation is used. Misuse of equipment, and failure to observe applicable codes and safe practices can result in serious personal injury and property damage.

## Introduction

Arc welding with coated electrodes is a manual process where the heat source consists of the electric arc. When the arc strikes between the coated electrode (by means of an electrode holder) and the piece to be welded (base material), it generates heat which causes rapid melting of both the base material and electrode.

The welding circuit consists essentially of the following elements:

- a power source
- an electrode holder
- coated electrodes
- an earth clamp and earth cables

as illustrated in figure 2 below.



figure 2

## The Power Source

The purpose of the power source is to feed the electric arc, which is present between the base material and the electrode, through the output of a current sufficient in quantity to keep the arc struck.

Electrode welding is based on the constant current principle i.e. the current delivered by the power source should not vary when the operator moves the electrode towards the piece. The main construction property of the source is therefore to keep the current unchanged in the presence of variations in arc length as the electrode moves closer to or away from the piece: the more constant the current, the more stable results the arc and the simpler the operator's work.

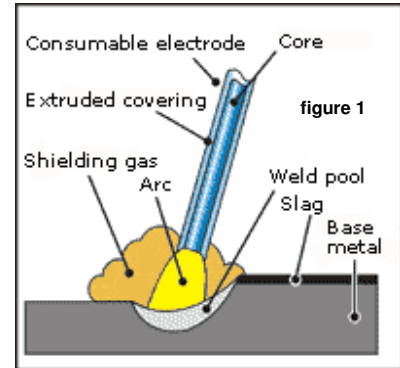

figure 1

Inside the power source, there is usually a welding current adjustment device, of a mechanical (e.g a magnetic shunt) or electronic type (SCR systems or inverter systems). This distinction can be used to classify electrode welding machines into three families, depending on their construction technology: electromechanical welding machines, electronic welding machines (SCR), inverter welding machines. The polarity of the power source output current distinguishes two further categories:

a) *direct current (DC) power source* (see figure 3)

The power source output current has a continuous wave form, which is obtained by means of a device, the rectifier, which is situated at the base of the transformer and can convert from alternating to direct current. This output is typical of electronic SCR and inverter power sources.

If the welding circuit has a direct current (DC) power source, it can be further classified according to the method of connecting the power source poles to the material to be welded:

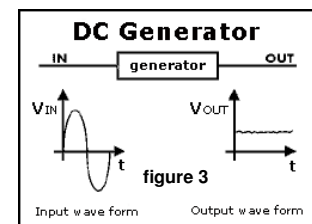

b) *alternating current (AC) power source* (see figure 4)

The power source output current takes the form of a sine wave, which changes its polarity at regular intervals, with a frequency of 50 or 60 cycles per second (Hertz). It is obtained using a transformer, which converts the mains current into a suitable current for welding. This is for electromechanical welding machines.

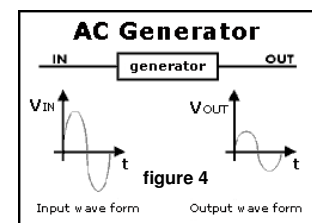

i) *straight polarity connection*

Straight polarity connection occurs when the clamp cable (with the electrode holder clamp) is connected to the negative pole (-) of the power source and the earth cable (with the earth clamp) to the positive pole (+) of the power source. The electric arc concentrates the heat produced on the piece and causes its melting. In this way, as the core of the electrode melts, it is deposited and penetrates into the welding joint.

ii) *reverse polarity connection*

Reverse polarity connection occurs when the clamp cable (with the electrode holder clamp) is connected to the positive pole (+) of the power source and the earth cable (with the earth clamp) to the negative pole (-) of the power source. The heat of the electric arc is mostly concentrated at the tip of the electrode. Each type of electrode requires a specific current type (AC or DC) and, in the case of DC current, a specific polarity: the choice of the electrode therefore depends on the type of power source used. Incorrect use will cause arc stability problems and hence also welding quality problems.

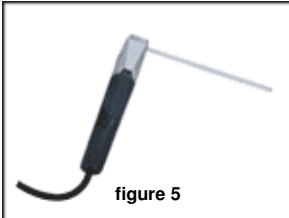

**electrode holder**

The primary function of the electrode holder is to support the electrode, guaranteeing a good electrical contact for current passage; it should also guarantee sufficient electrical insulation for the welding operator.

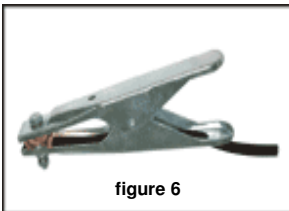

**earth clamp and cables**

The earth clamp is a tool that, via the earth cable, ensures the electrical circuit is closed between the welding power source and the piece to be welded. The clamp and earth cables, connected to the electrode holder and earth clamp respectively, permit an electrical connection between the power source and the base material to be welded. The choice of cable section and length should be based on the maximum welding current in amps.

**coated electrodes**

The coated electrode consists of a core and a coating. The core consists of a metal conductor rod whose sole purpose is to supply welding material to the piece. The material used depends on the base material: for carbon steels, for which electrode welding is most widespread, the core is in mild steel. During welding the core melts slightly before the coating does.

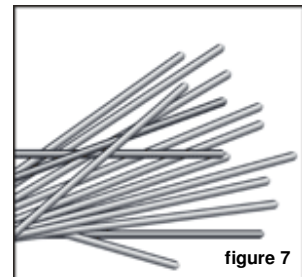

The coating is the most important part of the electrode and has many functions. It primarily serves to protect the weld from contamination, and it achieves this in two ways: i) By volatilizing, and then modifying the atmosphere surrounding the weld pool by delay melting, the core is consequently protected by the naturally formed crater; ii) by liquefying and floating on top of the pool, the bead is protected as it cools.

It also contains material capable of purifying the base material and elements that could contribute to the creation of alloys in the melt. The choice of coating is therefore very important and depends on the characteristics to be given to the weld. The coating can also contain weld material as a powder, to increase the quantity of deposited material and hence the welding rate. In this case we refer to high performance electrodes.

**modern power source features**

Modern inverter welding power sources may contain special features whose functions are to facilitate easier welding. These devices can include ‘arc force’, ‘hot start’ and ‘anti-stick’ technology.

An ‘arc force’ device eases the transfer of drops of melted material from the electrode to the base material, preventing the arc from extinguishing when the drops cause contact (i.e. a short circuit) between the electrode and the weld pool.

A ‘hot start’ device facilitates the striking of the electric arc, by supplying an ‘over-current’ every time welding restarts.

An ‘anti-stick’ device automatically switches off the power source if the electrode sticks to the base material, thus allowing it to be removed manually without ruining the electrode holder clamp.

## General Principles

Shielded metal-arc welding with the transformer welding machine depends upon the fundamental fact that when one side of the welding circuit is attached to a piece of steel, a welding electrode connected to the other side and the two brought into contact, an arc will be established. If the arc is properly controlled, the metal from the electrode will pass through the arc and be deposited on the steel. When the electrode is moved along the steel at the correct speed, the metal will deposit in a uniform layer called a bead. The electrodes used in welding are carefully manufactured to produce strong, sound welds. They consist of a core of steel wire, usually called mild since it contains a low (0.10-0.14) percentage of carbon. Around this core is applied a special coating which assists in creating the arc and at the same time protects the molten steel as it transfers across the arc.

In order to utilize these principals in metal-arc welding, some means of controlling the power is essential. The power in a circuit is measured by the voltage and current. However, the voltage is governed by the arc length and in turn depends on the electrode diameter. Therefore, the practical measure of the power, or heat, is in terms of the current, generally measured in amperes. Obviously a small electrode requires less current than a large one. To simplify operations the scale on the front of the welding machine is marked off for the various current values.

The exact current selected for a job depends upon the size of the pieces to be welded and the position of welding. Generally a lower current will be sufficient for welding on a small part than would be necessary to weld on a large piece of the same thickness. Similarly, with a given size of electrode a lower current should be used on thin metals than on the heavier sections.

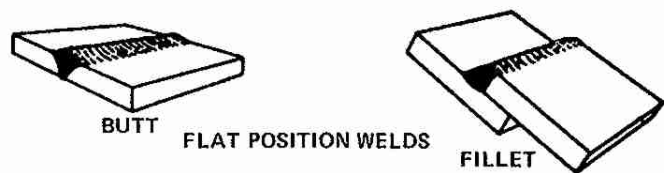

figure 8

While it is always a good policy to weld on work in the flat position, as shown in figure 8, occasionally, when working on machines or other large units it will be necessary to weld in a vertical, horizontal or overhead position as shown in figures 9, 10 and 11 respectively. Generally, under these difficult conditions it is helpful to reduce the current from the value used on welding in the flat position.

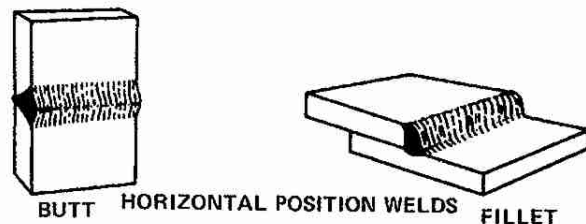

figure 9

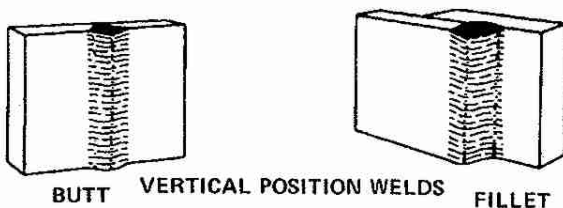

figure 10

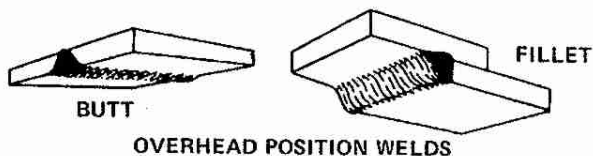

figure 11

In learning to weld there are certain fundamental steps, which must be mastered before one can attempt to weld on actual work. Preparatory to the actual striking of an arc, it is necessary to insert the electrode in the holder, as shown in figure 12.

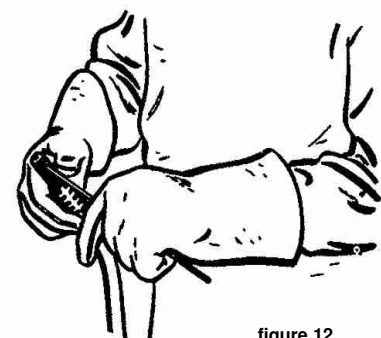

figure 12

## Arc Ignition

For striking an arc, figure 13 illustrates what is commonly known as the "scratching technique". In this method the striking end of the electrode is dragged across the work in a manner much the same as striking a match. When the electrode touches the work, the welding current starts. If held in this position, the electrode would

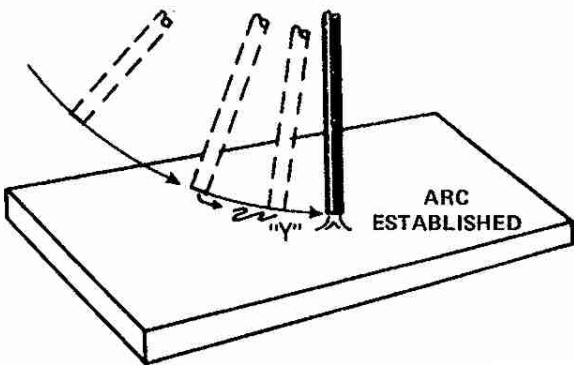

figure 13

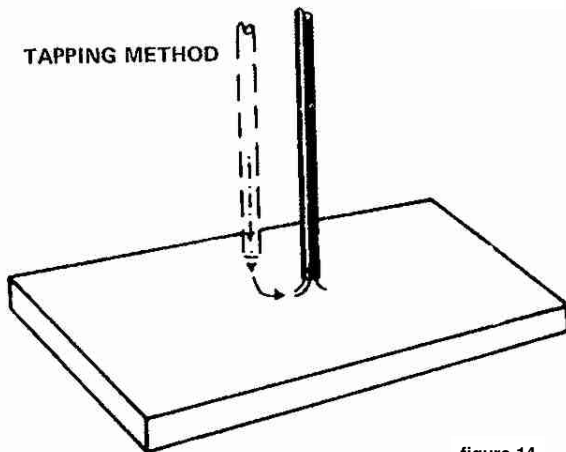

figure 14

"freeze" or weld itself to the work and to overcome this, the electrode is withdrawn from the work immediately after contact has been made.

The amount that the electrode is withdrawn is small and depends upon the diameter: this distance is known as the arc length. If in striking an arc, the electrode freezes, it may be freed by a quick twist of the wrist.

Another method of establishing the arc is available. It is known as the "tapping method" (see figure 14) where the electrode holder is brought straight down on the work and withdrawn straight after contact to the proper length.

Practice striking the arc using both methods. Generally the scratching method is preferred for a-c welding. Determination of the correct arc length is difficult since there is no ready means for measuring it. As a preliminary guide, use about 1.6mm arc length on 1.6mm and 2.4mm electrode; for 3.2mm and 4.0mm electrodes use about 3.2mm arc length. When skill is acquired, the sound of the arc will be a good guide. A short arc with correct current will give a sharp, crackling sound. Examination of the deposited bead will give a further check.

Once the knack of starting and holding an arc has been learned, turn next to depositing weld metal. In the beginning it is best to run beads of weld metal on flat plates using a full electrode. Practice moving from left to

right and from right to left. The electrode should be held more or less perpendicular to the work, except that tilting it ahead, in the direction of travel will prove helpful. The correct position is shown in figure 15. A proper bead is shown in figure 16 while figure 17 illustrates a cross section through the bead and identifies the various terms used in describing a weld. To produce these results it is necessary to hold a short arc, travel at a uniform speed, and feed the electrode downward at a constant rate as it melts.

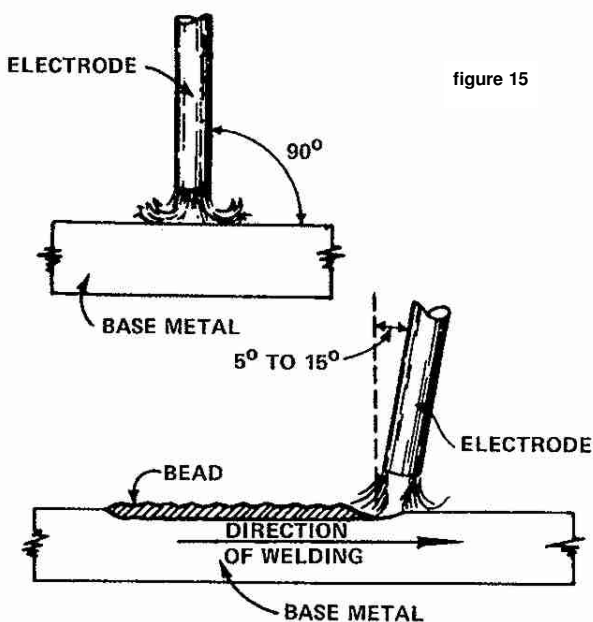

figure 15

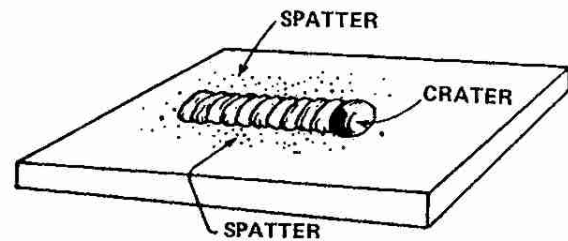

figure 16

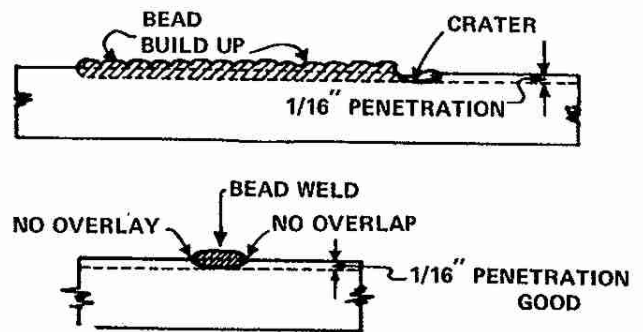

figure 17

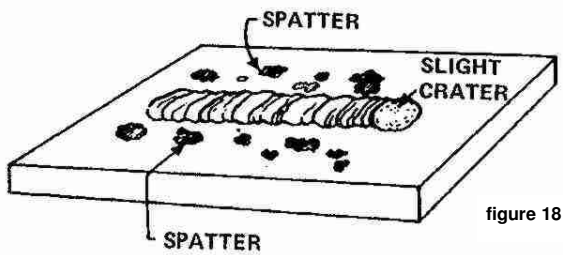

figure 18

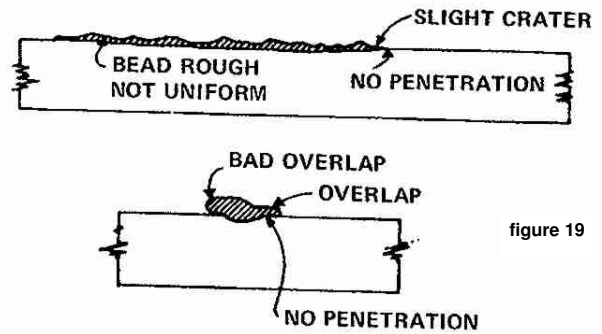

figure 19

Probably the first attempts in the practice will fall short of the results shown. Too long an arc will be held or the travel speed will vary from slow to fast and the welds will look like the one in figure 18. A cross-section through such a weld is given in figure 19. In addition the weld will probably be spongy (porous) and of low strength.

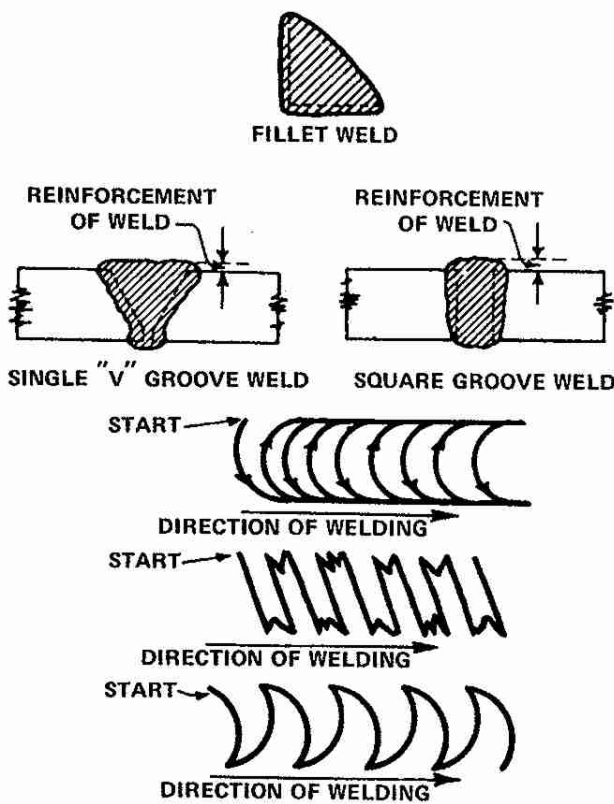

figure 20

Continue practicing until uniform beads as shown in figure 18 can be produced every time. A good method of practicing is to deposit a series of beads, one next to the other until the plate is covered. Then deposit another series of beads at right angles to the first, thus building up the plate to a greater thickness.

### Weaving

When it is necessary to cover a wider area in one pass of the electrode, a method known as weaving is employed. In this the electrode is moved or oscillated from side to side in a set pattern. In order to be sure of uniform deposits, it is necessary to use a definite pattern such as those illustrated in figure 20. While weaving is helpful, particularly when building up metal, it should be limited to weaves not exceeding 2.5 times the diameter of the electrode.

### Butt Joints

Up to this point the discussion has covered only the deposit of beads on the flat plates. While such operations are helpful in building

up worn parts or applying hard-facing materials, they do not help in learning to weld pieces together. For this purpose, other types of welds are illustrated in figure 21 are necessary.

In making bead welds, previously described, it was probably noted that the depositing of weld metal on one side of the plate caused it to "curl" up towards the weld: this is called distortion and will almost always be found when heat is applied locally to a metal plate. Similarly in making a butt weld distortion will cause the edges of the plate to draw together ahead of welding. This is caused by the contraction of the deposited weld metal on cooling. It may be overcome by spreading the edges apart on a long taper of about 3mm every 30cm.

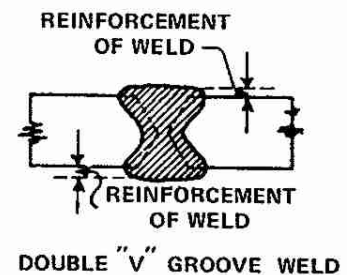

figure 21

In making welds in a butt joint, preparation of the edges may be necessary to ensure good results. In metal arc welding it is common practice to weld thin materials up to 4.8mm thick without any special preparation using the square groove butt joint. For thickness of 5mm and over the "V" groove either single or double is employed. Generally the single "V" groove will be satisfactory on thicknesses up to 18mm and in those cases, regardless of thickness, where one can work on the weld from one side only.

## Beveling

The best means for beveling steel for welding is by means of the oxy/acetylene cutting torch. The work may be done with a hand guided torch or special oxy/acetylene cutting machine. However, in performing this cutting, a scale will adhere to the plates. This must be removed by grinding or chipping before welding as it is likely to become entrapped and thus produce an unsound weld. Where oxy/acetylene cutting equipment is not available, grinding will probably be the best means of preparing bevels. The angles of these bevels should be about 30 degrees and the bottom edge may be left square for a distance of about 1.6mm. See figure 22.

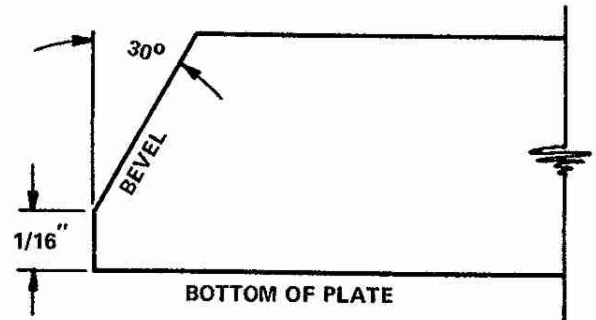

figure 22

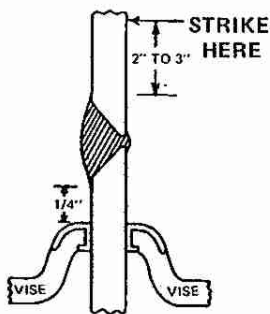

figure 23

Practice making butt welds starting on thin material about 3mm thick. Avoid very thin material (around 1.6mm thick) in the beginning, as this requires a fair degree of skill. Separate the squared edges of the 3mm material about 1.6mm and make a butt-weld all the way through with a 3.2mm electrode. Probably the first attempts will fail to penetrate the sheet or may burn through. Keep trying, adjusting the current within the recommended range: also vary the travel speed to give the desired weld. Having mastered the 3.2mm proceed to a similar exercise on a 6mm. This time, however, deposit a bead on each side of the joint and try to fuse one to the other. Since the weld from one side is in effect on 3.2mm thickness, no bevel is needed.

Next make a single 'V' groove on 6mm plate beveled 30 degrees. Start with a 3.2mm electrode for the first bead or layer and finish with a 9mm electrode. Be sure to penetrate about 0.8mm beyond the bottom of the 'V' (On these called the root). When skill has been acquired on the 6mm material, proceed to 9mm and then to 12mm. On these, particularly the 12mm, make also the double "V" butt joints. Generally speaking, it will be necessary to deposit a bead or layer for each 3.2mm thickness. On the heavier plates weaving of the top layers may be necessary to fill the groove completely.

When making practice butt welds it is wise to check the results occasionally. When elaborate testing equipment is not available, this may be done with a hammer and vice. Grip a short, welding piece with the weld just above the jaws. Hammer it in a direction that tends to open the bottom, root side of the weld, in the manner shown in figure 16. A good weld will not break under this test but will bend over.

If the weld breaks examine it to determine the cause. If there are a large number of holes – the weld looks spongy – it is porous and this is probably due to holding too long an arc. If there are bits of slag in the weld perhaps the arc was too short or the electrode was manipulated incorrectly thus permitting the molten slag from the coating to be trapped. This is quite likely to happen on a 'V' joint made in several layers and calls for thorough cleaning between layers. Perhaps on breaking it will be found that the original surface of the bevel is still evident. That means that it was not melted and the cause is quite likely to be found in too fast a travel speed or insufficient heat.

## Tee And Lap Joints

The other basic type of weld, the fillet weld, is used for making tee and lap joints. For this type of welding, no special preparation, other than squared edges, is necessary. Typical welded tee and lap joints are pictured in figures 24 and 25 respectively.

Considering the tee joint first, it will be seen immediately that the different locations of the piece creates a problem. The method of holding the electrode for butt welds will not be satisfactory. To deposit a single pass fillet weld hold the electrode as shown in figure 26. This will provide fusion into the corner and a fillet, the sides of which will be approximately equal. For maximum strength a fillet weld should be deposited on each side of the upright section. When a heavier fillet is needed, deposit a second layer as indicated in figure 27, using any of the weaving patterns in figure 28.

The lap joint, while involving the same fundamental weld type, the fillet, has metal distributed differently and therefore requires still another technique. The details of the application are given in figure 29, for a single pass weld. For a two-pass weld figure 30 provides the details.

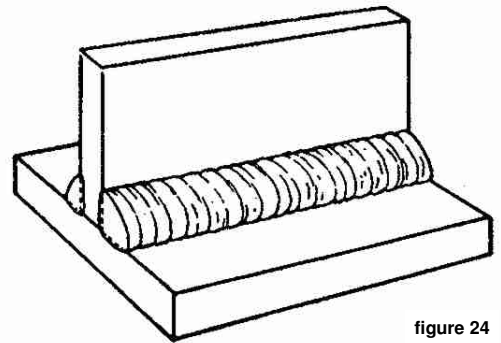

figure 24

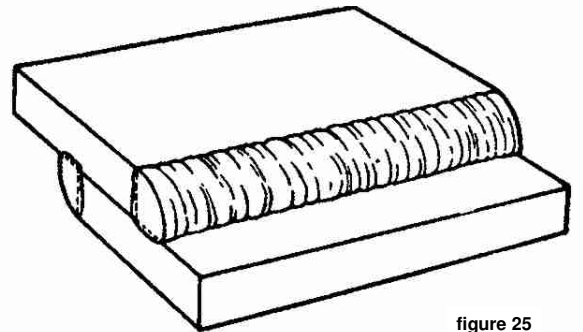

figure 25

ARC SHORT AND MOVED AT DEFINITE RATE OF SPEED—NO OSCILLATION

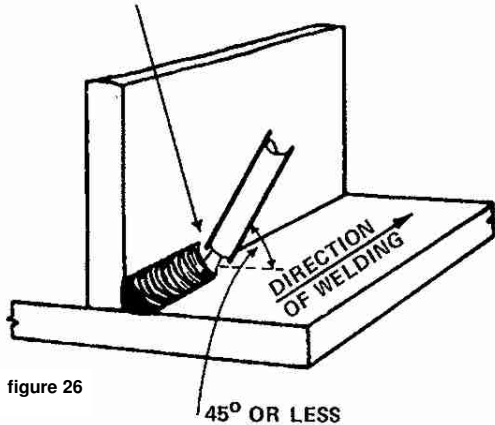

figure 26

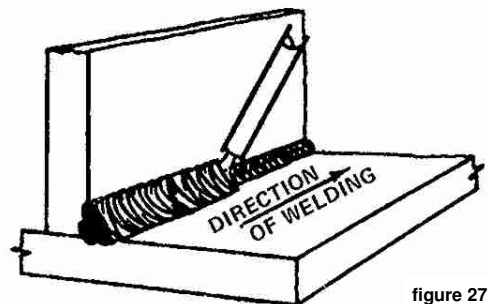

figure 27

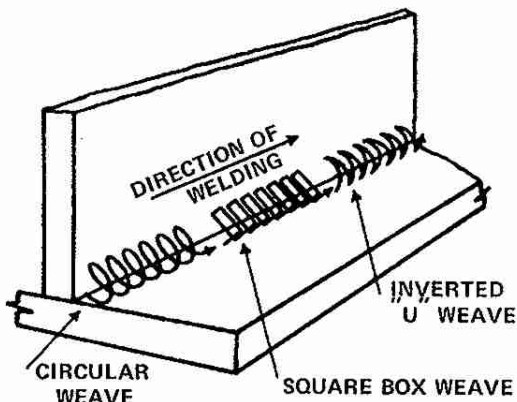

figure 28

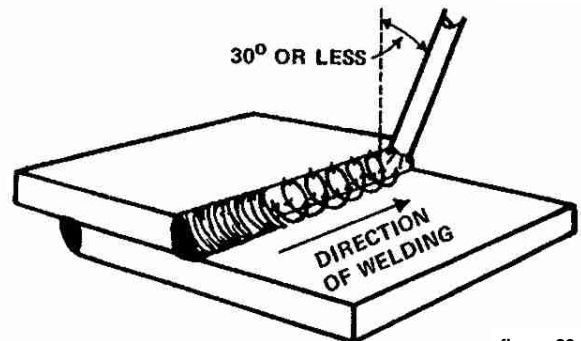

figure 29



figure 30



## Welding Vertically, Horizontally And Overhead

The importance of welding in the flat position, whenever possible, cannot be stressed too strongly. The quality of the weld is better, the operation easier and faster. However, occasions will arise when it is necessary to work on parts fixed in position under which condition welds must be deposited horizontally, vertically and overhead. It must be understood that welding in these positions is difficult and will require constant practice to develop skill.

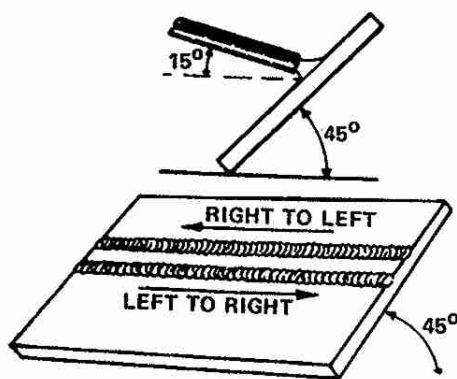

figure 31

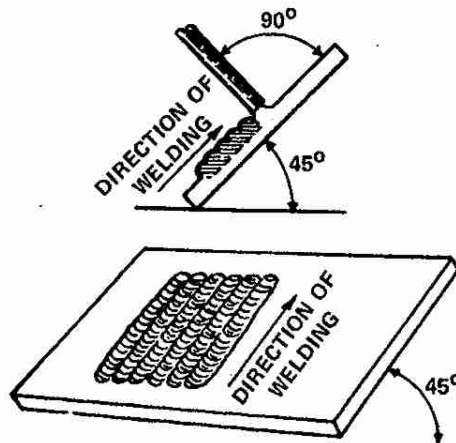

figure 32

As in the case of welding in the flat position, it is best to start practicing by first running bead welds in the various positions. Then as facility is gained on these operations practice may be continued on butt and fillet welds (tee and lap joints) in these positions.

One of the first facts noted when welding in these positions is that the force of gravity tends to cause the molten metal to drip (fall) down. The technique

used, therefore, must be designed to overcome this and since it is difficult it is best to approach this by steps. To accomplish this, start by making horizontal bead welds on plates inclined at 45 degrees as shown in figure 31. When this has been mastered so that uniform beads can be made consistently, practice on welding vertically may be started. Again begin with an easy operation such as running beads vertically on plates set at 45 degrees – see figure 32.

To progress with this practice it is necessary now to move the plates into vertical position. The details of horizontal bead welds are given in figure 33.

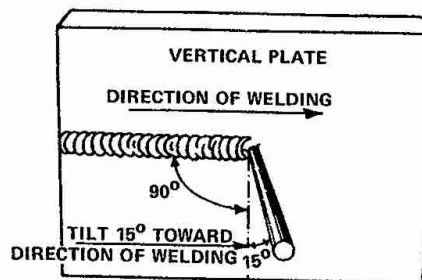

figure 33

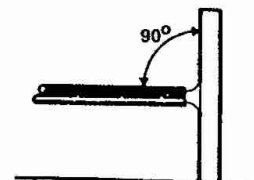
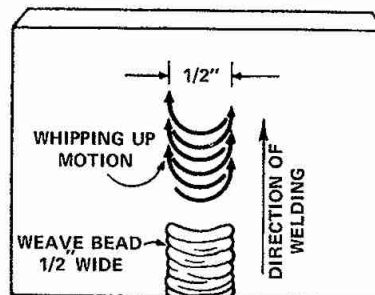

figure 34

Welding vertically may be performed either by carrying the weld upward or starting from the top and welding down. It is generally conceded that working upward is easier, and therefore, bead welds in this manner should be practiced. A method for making weave beads is illustrated in figure 34.



Since bead welds are of limited practical value, this experience must be extended by practicing on butt welds in the vertical and horizontal patterns.

Figure 35 provides information suitable for a single pass vertical butt weld or the first pass of a multiple layer deposit. Two methods of depositing the subsequent layers are given in figures 36 and 37.

For horizontal welds the details are shown in the collection in Figure 38. Note that a strip of metal is shown at the root of the weld, this is known as the backing strip. Its use permits the securing of a sound root pass without great difficulty. In use, the beveled plate edges should be spaced on the backing strip and the strip tack welded to the plates on the reverse side.

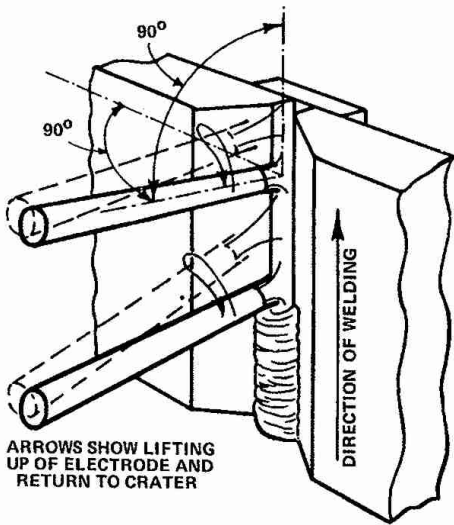

figure 35

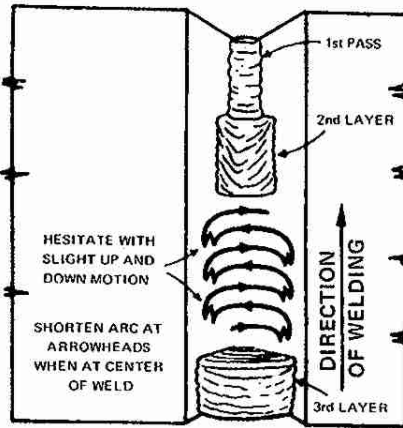

figure 36

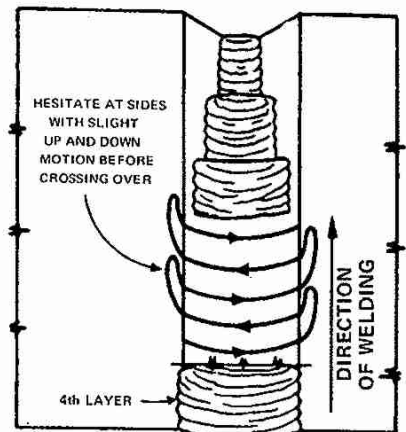

figure 37

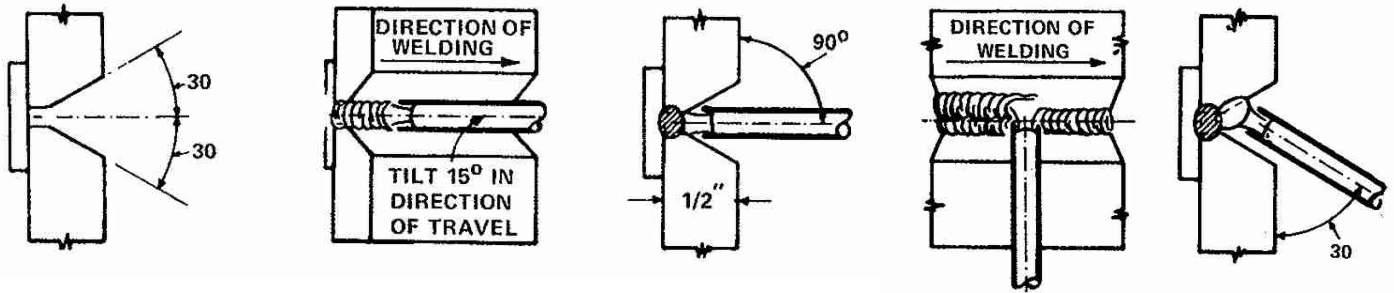
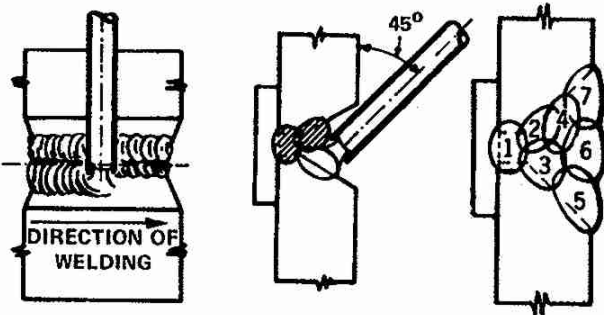

figure 38



For fillet welds on tee joints the technique is shown in figure 39. For vertical lap joints the same technique may be employed notwithstanding the difference in positions of the plates. Also when depositing a multilayer fillet weld, this same method would be used to deposit the first layer on both lap and tee joints. For depositing subsequent layers on tee joints two means are used and are shown in figures 40 and 41. For the additional layers on lap joints a somewhat similar weave may be seen in figure 42.

Welding in the overhead position is the final problem to master. Again proceed through the steps of making bead welds, the making of butt welds and finally the making of fillet welds.

When weaving is necessary, the pattern in figure 43 may be used.

The technique for overhead butt welds is illustrated in figure 44 this covers single pass welds or the first pass of multilayer welds.

Subsequent beads may be deposited as shown in figure 45.

Again the technique for fillet welds may be employed for welding lap joints.

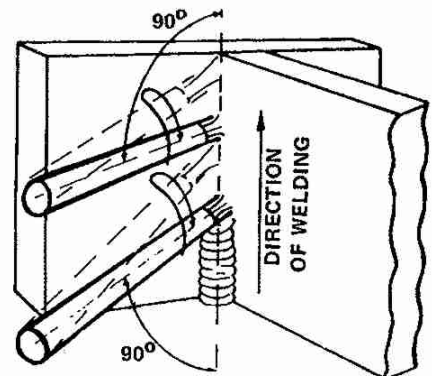

figure 39

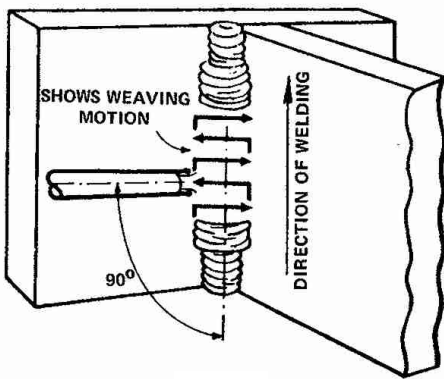

figure 40

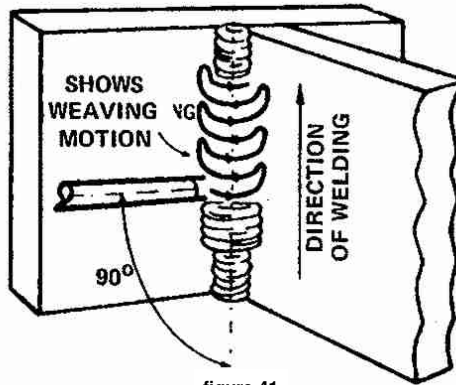

figure 41

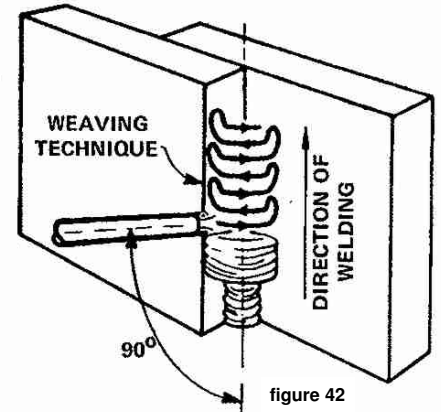

figure 42

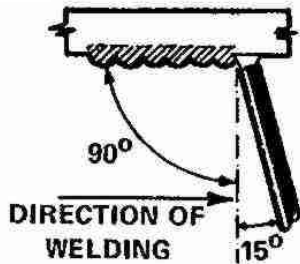

figure 43

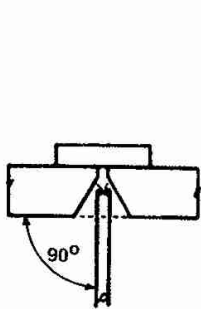
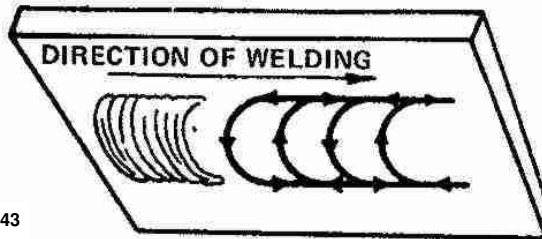

figure 44

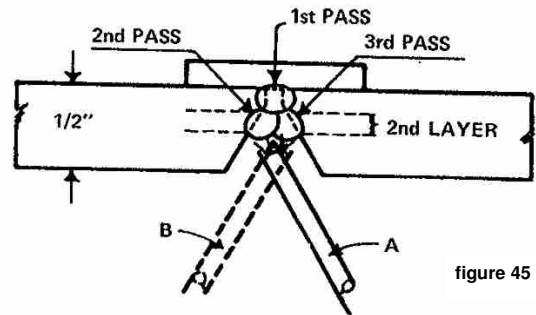
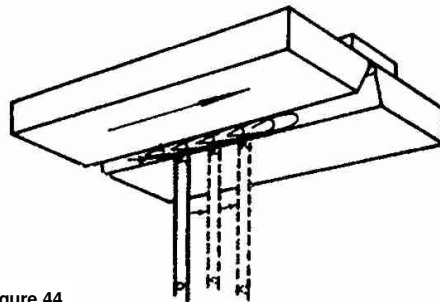

figure 45

## Conclusion

It may be appreciated that no printed instruction can impart to the beginner the skill necessary for successful welding. Personal instruction by an experienced welding operator is the best means described to date for accomplishing this end. Therefore, an effort should be made to secure some facility for instruction and practice under competent supervision. In any event the beginner should at least secure the benefit of criticism of finished welds by a qualified welder.

| ROD  | ROD DIAMETERS |          |          |          |
|------|---------------|----------|----------|----------|
|      | 1.6MM         | 2.4MM    | 2.5MM    | 4.0MM    |
| 6013 | 20-45A        | 40-90A   | 80-130A  | 105-180A |
| 7018 | 30-50A        | 65-100A  | 110-165A | 150-220A |
| 7024 | n/a           | 100-145A | 140-190A | 180-250A |
| NiCl | n/a           | 50-70A   | 65-85A   | 100-140A |
| 308L | n/a           | 40-80A   | 75-115A  | 105-160A |
| 312  | n/a           | 60-90A   | 80-120A  | 110-160A |
| 600  | n/a           | n/a      | 110-140A | 140-180A |

chart 1 : welding electrode current range (AMPS)

| ROD  | AC  | DC  | POSITION   | PENETRATION | USAGE AND WELDABILITY              |
|------|-----|-----|------------|-------------|------------------------------------|
| 6013 | YES | +/- | ALL        | MED         | GENERAL MILD STEELS, EASY          |
| 7018 | YES | +   | ALL        | MED         | LOW HYDROGEN, MILD STEELS, STRONG  |
| 7024 | YES | +/- | FLAT/HORIZ | MED         | MILD STEELS, SMOOTH, EASY, FASTER  |
| NiCl | YES | +   | ALL        | MED         | CAST IRON                          |
| 308L | YES | +   | ALL        | MED         | STAINLESS                          |
| 312  | YES | +   | ALL        | LOW         | DISIMILAR, MILD & STAINLESS STEELS |
| 600  | NO  | +   | ALL        | LOW         | HARDFACING                         |

chart 2 : welding electrode selection and features